

DO NOT SCALE PRINT

DIMENSIONS AND TOLERANCES IN ACCORDANCE WITH ASME Y14.5M-1994

WAS NO.

DRAWING NO.

CON-604

| REVISION | PART NO. | 'L' | CONTACT PLATING |
|-------------------|-----------|--------|-----------------|
| | CON-604-1 | 18.00 | |
| | -2 | 24.00 | |
| | -3 | 60.00 | |
| | -4 | 36.00 | |
| | -5 | 00.00 | |
| | -6 | 48.00 | |
| INACTIVE | -7 | 360.00 | |
| | -8 | 72.00 | |
| INACTIVE | -9 | 40.00 | |
| | -10 | 30.00 | |
| | -11 | 96.00 | |
| 15605,9-15-92 | -12 | 80.00 | |
| | -13 | 120.00 | |
| | -14 | 192.00 | |
| OBSOLETE | -15 | 00.00 | |
| 22565 10-22-01 | -16 | 30.00 | GOLD |
| 22565 10-22-01 | -17 | 72.00 | GOLD |

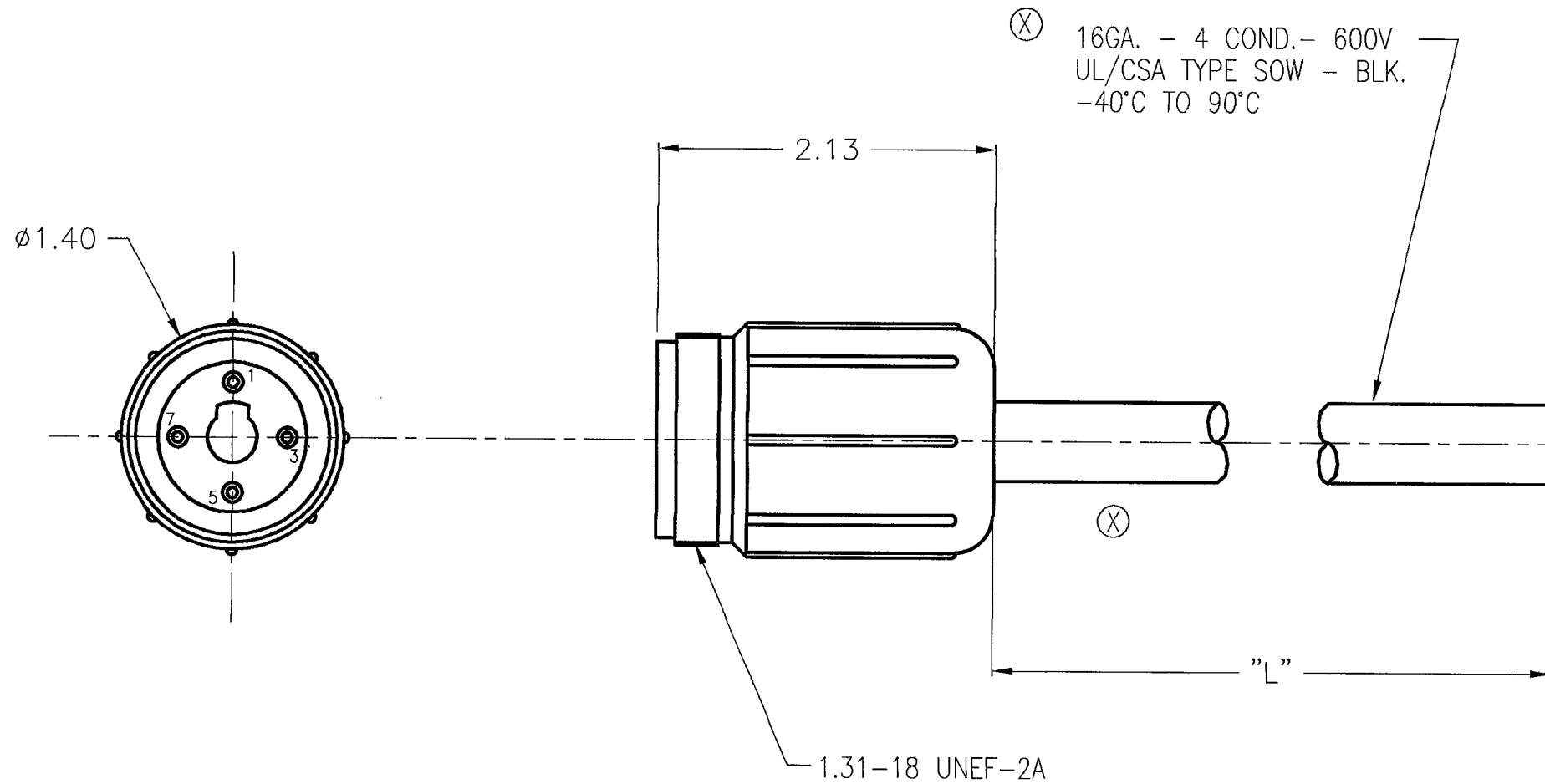

| PIN | COLOR |
|-----|-------|
| 1 | BLK |
| 3 | GRN |
| 5 | RED |
| 7 | WHT |

NOTICE
THIS DRAWING IS THE PROPERTY OF QUALITROL CORPORATION AND IS LOANED ONLY ON THE CONDITION THAT IT WILL BE USED TO FACILITATE THE PURPOSE FOR WHICH IT WAS INTENDED AND NOT BE REPRODUCED, COPIED OR OTHERWISE DISPOSED OF, AND IS NOT TO BE USED IN WHOLE OR PART FOR FURNISHING INFORMATION RELATIVE TO THE MAKING OF DRAWINGS, PARTS, APPARATUS OR PARTS THEREOF, EXCEPT BY WRITTEN ORDER FROM QUALITROL CORPORATION.

| LET | DATE | ALTERATION | C.N. |
|-----|----------|---|-------|
| - | 10-19-00 | (REFERS TO PTS.-16 & 17 ONLY) NOTE 1: TIN PLATE WAS SILVER PLATE | 21684 |
| - | 12-17-98 | REVISED CABLE SPECS. | 19894 |
| X | 10-10-91 | UPDATED | 15108 |
| W | 4-3-91 | REDRAWN | 14727 |

TITLE: 4 COND. CONNECTOR
STD. QUALITROL (#16 GA.)

MATERIAL:

FINISH:

SCALE: 1:1

SHEET 1 OF 1

DRAWING NO. **CON-604**

TOLERANCE UNLESS NOTED:
2 PLC.DECIMAL +/- .02
3 PLC.DECIMAL +/- .005
ANGULAR +/- 2 DEG.

QUALITROL
CORPORATION
FAIRPORT, NEW YORK

| | | | |
|-------|-----|------|----------|
| DRAWN | MFS | DATE | 1-30-91 |
| CHECK | TWE | | 10-15-91 |
| APP'D | - | | - |